



SmartTech pvt. Ltd.
COMPLETE SOLUTION FOR APPAREL INDUSTRY



www.smarttechbd.net

Dear Valued Customer

Smarttech (Pvt) Ltd. is one of the leading importer and indenting companies in Bangladesh, emerged in 2007. We have earned the trust of our customers by providing qualityful and world renowned machineries from Europe and Asia with the alliance of Italy, Germany, Korea, China etc. We are offering garments and textile machineries like Industrial sewing, special attachment and automatic machineries to improve productivity and efficiency and in addition, garment washing and dyeing machineries etc. Thus, it has been our endeavour to offer you the best equipment and parts you need at a competitive rate. We also have been dedicated to offer you the best service by our own technical team. They are always ready to meet the challenging technical needs by cultivating innovative thoughts. To be more specific our marketing, technical and quality assurance professionals provide proactive and quality services with a commitment that can transform your dream into reality.

Over the years, our success lies in the expertise of our professionals, passion to understand our customers and ability to exceed their expectations. Additionally, we are very much pleased to welcome you to the display of our in housed 'Garments Finishing Machineries' under 'SMIT' Bangladesh Brand. We are always looking forward to earn your patronage through our world of quality services & world renowned machineries with innovative technologies.

Sales & Project & Service

Phase 1

Layout Design & Planning for Complete Project Offer from Cutting to Finishing

Layout Including Washing & Dry Processing with Minimum Energy Consumption

Phase 2

Machine Installation

Designing Maintenance Activity & Operator Training

Phase 3

Regular Maintenance & In Situ Service

Technology Bridging & Incorporation of New Technology to Increase Worker Efficiency



GROZ-BECKERT®











Machine Needles (SMN/HN) From Germany

Needle Measuring System Comparison

Number NR:	DIA MM	Number Metric NM
6	0.50*	50
7	0.55*	55
8	0.60	60
9	0.65	65
10	0.70	70
11	0.75	75
12	0.80	80
13	0.85	85
14	0.90	90
15	0.95	95
16	1.00	100
17	1.05	105
18	1.10	110
19	1.20	120
20	1.25	125
21	1.30	130
22	1.40	140
	1.50	150
23	1.60	160
	1.70	170
24	1.80	180
	1.90	190
25	2.00	200

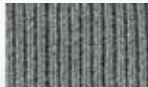

GROZ-BECKERT CLOTH POINTS

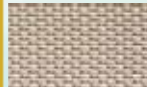
RS	R	RG	FFG/SES	FG/SUK	SKL
					
					
Sharp round point	Regular round point	Round point with	Light ball point	Medium ball point	Special ball point
Standard for blindstitch needles. For precise stitch sequences in lockstitch operations. A sensitive point. susceptible to damage. Example: Blouses, fine skirts and trousers, curtains	Most common for all kinds of lockstitch application (FST 301) particularly for woven fabrics, artificial leather, coated fabrics. Example: Shirts, Trousers, various kinds of garments.	slightly rounded tip standart for all chainstitch operations (FST 401 & 406) Example: For fine, sensitive knitted fabrics microbire, multi-head embroidery.	For knitted fabrics and for wovens. Example: T-Shirts, underwear, fine sweaters.	For elastic fabrics with rub-ber of elastmeric contents Example: Sweaters, lace underwear, Schiffl embroidery	For warp fabric with high elastomeric contents. Example: underwear, orthopaedic clothes





Morgan Fashion technology

Morgan Tecnica offers the largest and most modern range of solutions for the cutting room. Several models of roll loading and handling systems, automatic spreaders, spreading tables, labellers, automatic cutters with different lay thickness, from 2,5 to 9 cm and plotters. Software for CAD, Cut Order Planning, PDM and Virtual Fitting.

FUSION LINE : REAL TIME DATA ANALYTICS

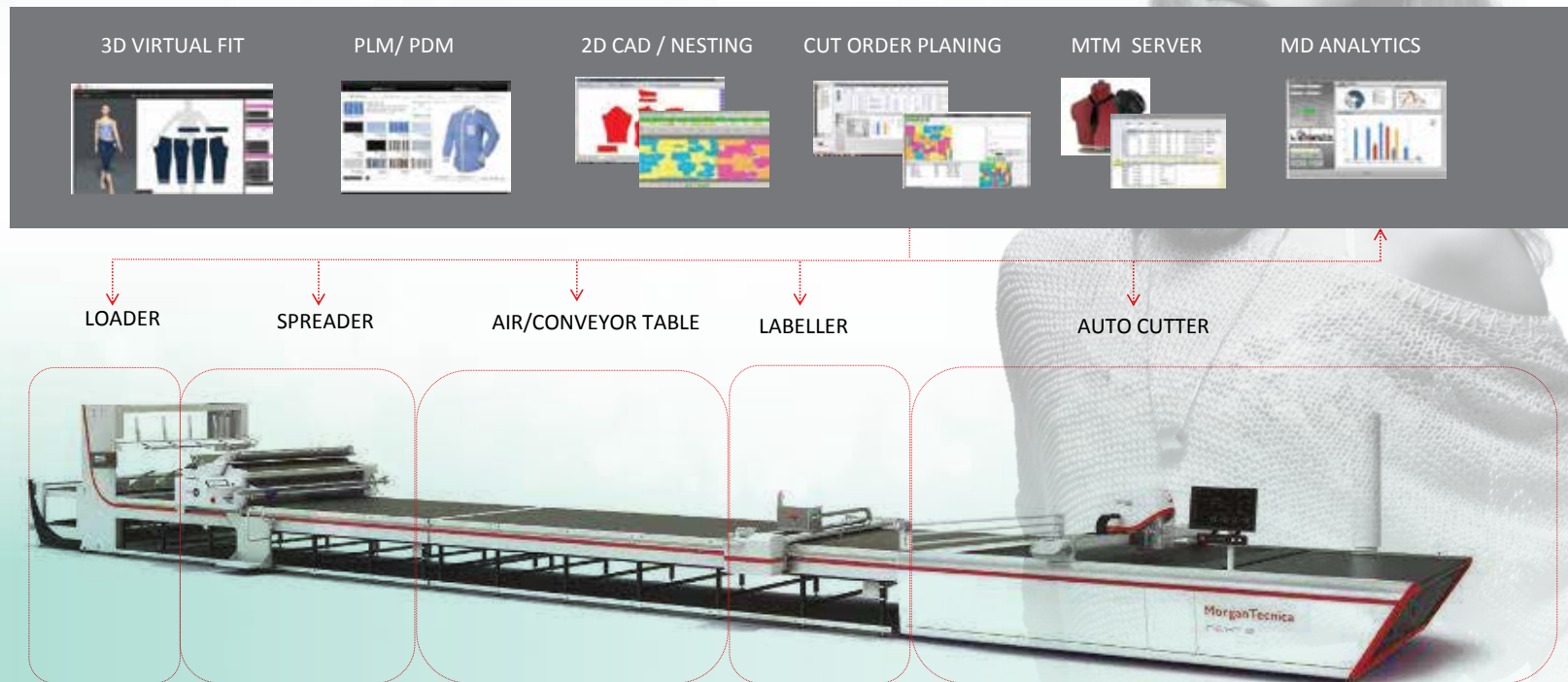

WITH MORGAN'S
INTEGRATED SOLUTIONS

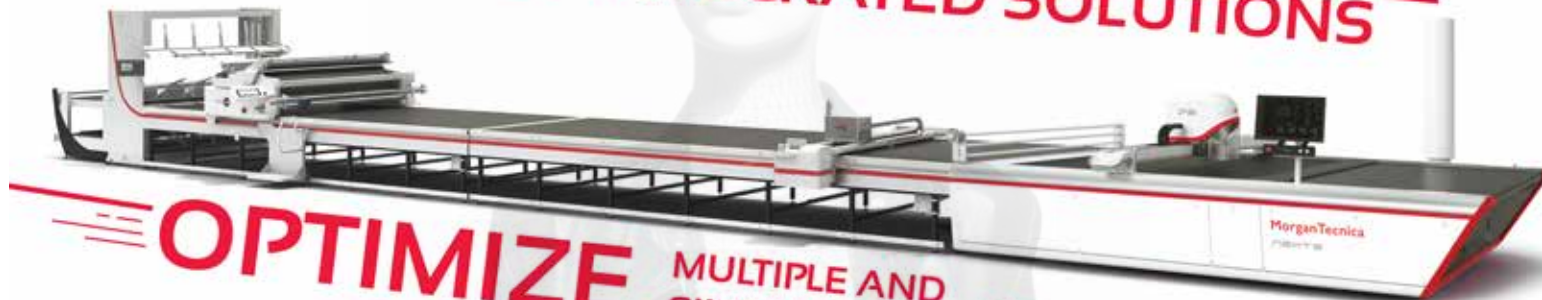

OPTIMIZE MULTIPLE AND
SINGLE ORDER PRODUCTION



CUTPLAN
MD CAD
FOX 50
FOX 100
NEXT 25
NEXT 50
NEXT 70
NEXT 90



CUTPLAN
MD CAD
330 LOADER
316 LOADER
TWIST 60
FOX 50
PIN TABLE
NEXT 25
NEXT 50
NEXT 70



CUTPLAN
MD CAD
FOX 50
FOX 200
NEXT 70HM
NEXT 70
NEXT 90



CUTPLAN
2D CAD
316 LOADER
FOX 200
NEXT 70HM
PLY 1



CUTPLAN
2D CAD
FOX 50
TWIST
NEXT 25
NEXT 50 LINGERIE



CUTPLAN
2D CAD
316 LOADER
FOX 200
PLY 1
NEXT 25
NEXT 70HM



CUTPLAN
2D CAD
316 LOADER
FOX 200
PLY1
NEXT 25
NEXT 70HM



Machinery VizPATTERN

Digital Pattern Viewer

ES-870-10

> Visual display of patterns in real scale

> DXF import and Model/Pattern Library

> Visual measure tool

> Inspection data management



S O F T W A R E H U B



DESIGNING

Collection Planning · **PLM**
Sketching · **Sketcher**
Fabric Texture Creation · **Painter**
Virtual Styling · **3Dress**
Virtual Presentation · **3DViewer**



PROTOTYPING

Virtual Prototyping · **3Dress**
Presentation of Virtual Collection · **3DViewer**
Pattern Designing · **2Design**
Casting and Fabric Booking · **COP + Best Nest**
Bill of Material and Tech Pack · **PDM**



PRODUCTION

Virtual Sampling · **3DViewer**
Supply Chain Management · **PLM**
Workflow Control · **PLM**
Cut Order Planning · **COP**
Cutting Room Organization · **COP**
Cutting Room Analysis · **Morgan Analytics**
Quality Inspection · **PLM**
Social Compliance · **PLM**



SALES

E-commerce solution · **3Dress Shop**



LOIVA Attachments & Special Machine

LOIVA is a manufacturer of special type industrial sewing machines & attachments: button wrapping, knotting machine, button feeder attachment, autojig machines, digital pullers etc.



LV-6200

Single Needle Lock Stitch Machine for Hidden/Ditch Stitch Operation



MJ-3400

Single needle lock stitch machine for making collar, cuff, flap, waistband etc.



LV-20

Button Wrapping and Knotting Machine



PERFECT POSITIONING OF
BUTTON TO STITCHING MACHINE
FOR HIGHER PRODUCTIVITY

ST-12

Industrial sewing machine attachment digitally controlled fully programmable button feeder attachment



FD Series

Pneumatic Edge Guide for Attachment for Overlock Machine

H&H ASIA GROUP LIMITED

SINCE 1993



Your Bonding Expert

The company was established in 1993, and hence we have over 27 years of experience for thermoplastic technology on seam sealing and adhesive film applications. We are specialise in thermoplastic technology for sew free production. Use of adhesive and Waterproof technology for manufacturing of clothings, bags, shoes, material for medicals, tents and gloves etc. Are priority in our mind... that include waterproof seam sealing, sew free pocket adhesive, zipper bonding, front zip sealing, fabric joining, line bonding, overlay taping, and also adhesive backing for woven label and embroidery... We can offer consultant support depends on the situation of customers. Now, we have several hundred customers and installation sites all over the world.



- * Intimate Wear
- * Pro-Active Wear
- * Outerwear
- * Sports Wear
- * Fashion Wear
- * Smart Casual Wear
- * Smart Formal Wear
- * Camping
- * Shoes
- * Bags



US-512 Ultrasonic Rotary
Welding Machine

SINCE 1993



Your Bonding Expert

Seam Sealing Family



AI-103



AI-118

Bonding Family



SF-816



SF-828



CS-653



CS-661



CS-667



CS-729 (Zipper Press)



CS-709



CS-703

Industrial Sewing Machine

More than 100 years, Brother is striving technology development to widen the possibility of sewing machine.



Single Needle Direct Drive Lock Stitcher



Twin Needle Lock Stitch Sewing Machine



Feed Off the Arm Double Chain Stitcher



Zigzag Lock Stitch Sewing Machine



Direct Drive Lockstitch Bar Tacker



Buttonhole Sewing Machine



Button Attaching Machine



Electronic Eyelet Button Holer



Programmable Electronic Pattern Sewing Machine



Blind Stitch Sewing Machine



Real & Fake Down Filling



Four Nozzles Down Filling Machinery
DF-4403X



Garments Template Cutting



JWEI RC03
Apparel Template
Cutting Machine





Han's Yueming Group

Han's Yueming Laser has obtained 149 patents and utility model patents and got a number of science and technology progress award in Guangdong province, whose product system has covered the eight major industries, seven series and nearly eighty categories of product clusters and more than thirty industry application solution program.



Y Type
Conveyor Auto-
feeding Laser
Cutting Machine



Camera
Positioning
Cutting Machine



SUNGWOO SEWING MACHINE

We are pleased to inform you that we (United Technology) are the agent of Korean based Sungwoo brand Digital Puller for industrial sewing machine



JEAN, ETC..

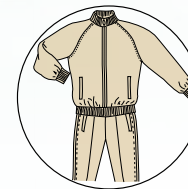

SPORTS WEAR, ETC..

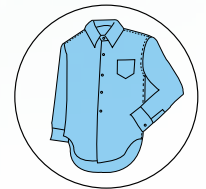

MAN'S SHIRT, ETC..



Feed off the Arm Series



Seungmin

We continue in taking on challenges and developing new technology to achieve our goal of gaining a worldwide reputation for excellence.



SM 600-N

Prong Pearl Snap Machine for Y-Shirts and Infant's Apparel



SM 800-6H

Automatic Spangle Motif Setting Machine



SM 888-N

Ultrasonic Hot-Fix Setting Machine



Garment Finishing Technologies

For 37 years Tonello have been a reference point for the most important laundry and dyeing companies all over the world and for fashion brands – it's because they don't simply make machines but produce ideas.

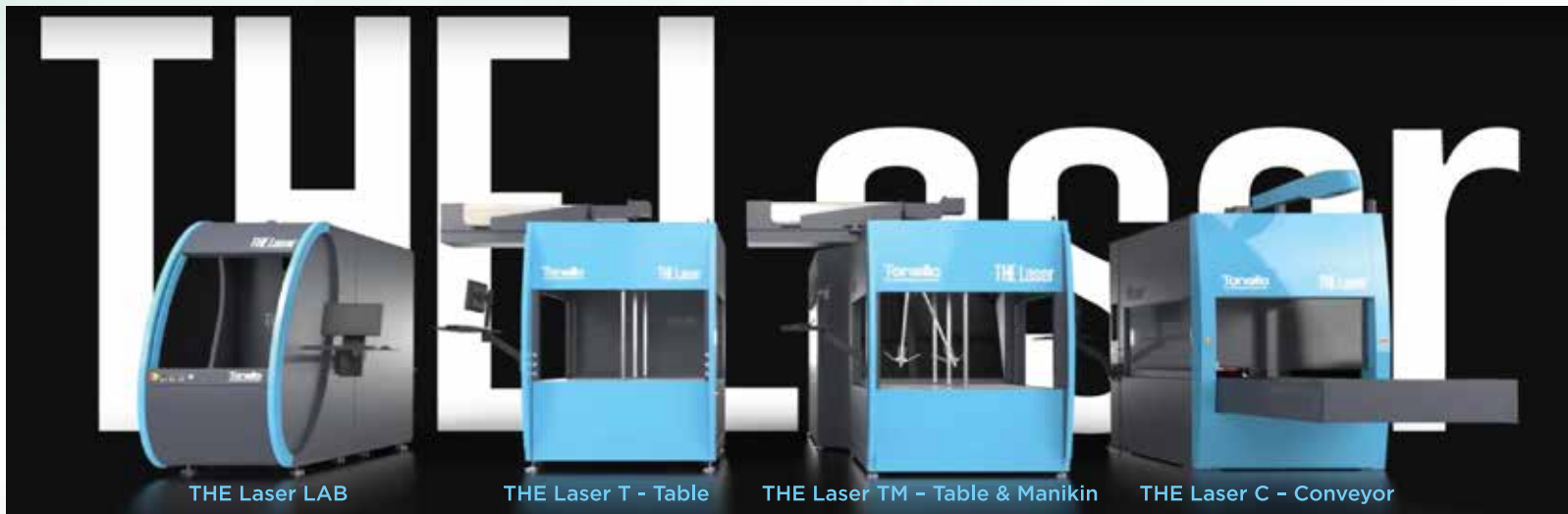

THE Laser LAB

THE Laser T - Table

THE Laser TM - Table & Manikin

THE Laser C - Conveyor

Created by *designers for designers*, smart, modern and user-friendly, possible to create new projects quickly and easily and start production immediately

brand new graphic interface and tools studied and developed together with technicians and laser designers from all over the world,

simplified and automated functions

wash effect tool that allows you to see the final result of laser marking, on washed garments, even before marking

blur, crop, free transform, production mode, damage filters, erase, wash effect, smudge, scraping filters, brush

SOFTWARE



MAIN FEATURES

HD Mode

In the HD mode the laser works with great precision to realize even the thinnest and tiniest details. This includes lines, dots, illustrations and logos.

100% natural look

THE Laser can create the most accurate and natural looking effects. This is thanks to the most sophisticated marking technologies, the new functions of the Crea software and when working with mannequin, the 360° effect.

Design Library

The rich library of laser designs gives access to an infinite number of creative combinations that will help you start your production right away and easily create new projects.

Laser fabric test

The Laser Fabric Test shows the reaction of a fabric to all possible laser finishes. This, in order to identify in a fast and responsive way the most appropriate settings to choose.

smart-Warp

The Smart mode reduces roasting time by 30%, while the Waro mode even has them when there are strongly contrasting effects



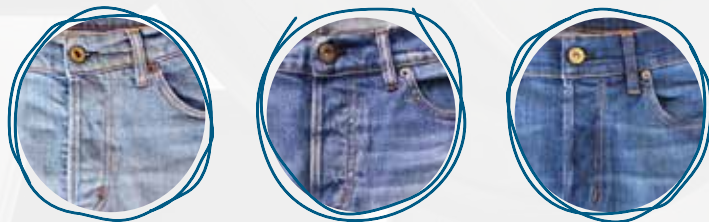
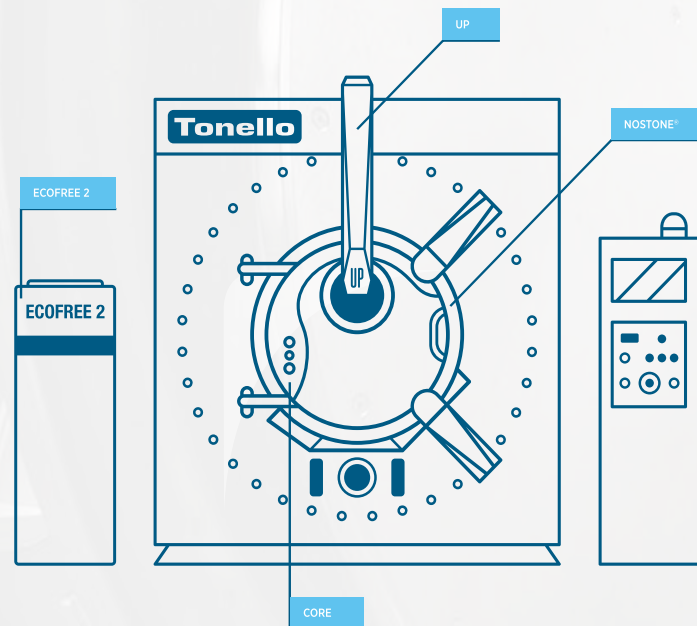

EVERYTHING YOU NEED IN A SINGLE MACHINE

A harmonious and functional set of perfectly integrated technologies, all in the same machine. For a long series of advantages.

A single machine for performing all the finishing operations on the garment: this is the path that we have chosen to tangibly respond to the market's most sophisticated demands, with an approach oriented towards sustainability, transparency and flexibility. Because the **all-in-one system** has been created specifically in order to adapt to the most diverse necessities.

The system saves energy, reducing water and chemical consumption, cutting down processing times and total production costs: respecting the environment, reducing manual labor and protecting the health of operators.



ECOFREE 2 is the latest washing technology using ozone in the water and ozone in the air, the definitive treatment. This guarantees the best performance on the garment, fewer manual operations and a huge reduction in water and chemical consumption.

+



NOSTONE® allows obtaining a stone-washed effect without using pumice stone (and therefore without pumice's disadvantages, both economic and environmental). Other pluses include less water needed for purification and no more sludge to dispose of.

+



UP optimizes garment washing, reducing the liquor ratio to levels never seen before (LR 2:1). It also drastically reduces energy consumption, reducing processing times and costs.

+



CORE permits creating effects and applying products to garments, increasing performance and reducing water consumption by up to 96%. Impressive savings in product use and shorter processing times are the other benefits.

Tonello
THE INSPIRING COMPANY

O3 BLEACH
THE REAL OZONE BLEACH

THE REAL BLEACH WITHOUT BLEACH



Tonello customers owning the All-in-One System will already be able to enjoy the OBLEACH effect and feel protected by the patent of the process.

OBLEACH: MAIN ADVANTAGES



Sustainable bleach using ozone
(no PP, no chlorine)



Respect for the fibers and the environment,
thanks to a room-temperature process



Authentic effects with great contrast



Maximum reproducibility,
allowed by the technology

OBLEACH: THE TECHNOLOGY

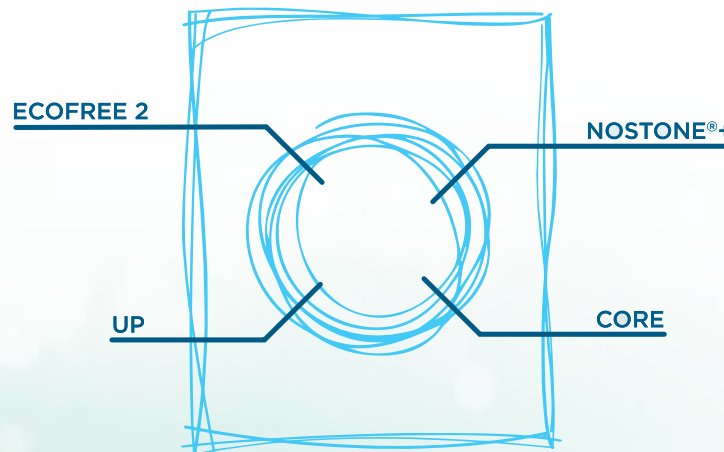

OBLEACH is possible thanks to the **All-in-One system**, a single machine that contains the most recent generation of finishing technologies: ECOfree 2, NoStone®+, UP and Core.

ROTARY DYERS & TUMBLERS



MOVEMENT SYSTEMS

We offer three models of movement systems: shuttle for garments loading, unloading belt to lead the garments to the collection point, moving conveyor from the washing machines to the dryers. The three movement systems optimize both the times and the works of the operators, automating the laundry.



Curing Oven & Dryer

For over 45 years, we have been designing, manufacturing and marketing dryers for the fashion industry. Some things are always the same: the quality, the desire to stand out, the desire to grow. Others, on the other hand, are constantly changing: technologies, software, skills.



OPTIONAL





Infra-red

Any fabric is dry when it reaches a certain temperature. This infra-red system automatically determines the cycle once the pre-set temperature is reached.



Humidity control with instrument EWTT3 / U
 Programmable humidity controller, which detects the outlet air thereby determining the drying degree of the garments. The drying cycle finishes once the pre-set residual humidity value has been reached.



Touch-screen

Control panel with touch sensitive screen which allows to easily set the drying programs and to control in real time the machine functioning.

-20%

STEAM CONSUMPTION*



-18%

ENERGY CONSUMPTION*

GREEN DRYER

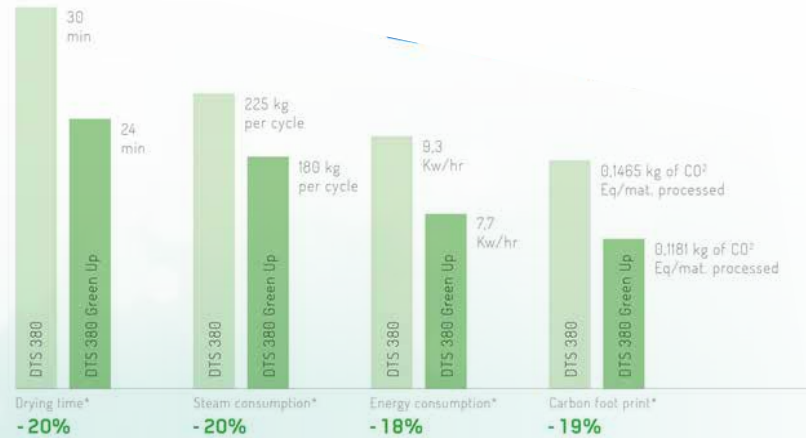

* Material: cotton shirt • Loading weight: 170 kg • Steam bar: 8 • Humidity: 55%.

Automatic Sewing Machine

VI.BE.MAC.'s automatic units has some important features, such as:

- high and time-constant quality;
- high hourly production;
- flexibility;
- reduction of workers' number;
- low management cost



4650EV9@UP2
Automatic Belt Loop Setter



V300
Automatic continuous waistband unit



2516v4
Automatic back pocket setter



VC101HAM
Back Pocket Creaser



V900.1
Automatic Eyelet Button Hole Unit



2261HP
Feed of the arm Unit



V364.1
flat bed felling unit



V800
Automatic side seam serging unit



3022BHE
Bottom hemming unit



V700
Automatic pocket hemming unit 2CS



Veit for Iron & Finishing Machine

From ironing tables and steam generators to high-pressure steam irons; from fusing machines to hot and cold 3-dimensional form finishers;



Texprocess Innovation Award 2015 goes to VEIT Fusing 4.0



Veit Varioset Flat Top Table S+B



Industrial Steam Iron VEIT HP2003



The new Pants Finisher / Blower Topper generation VEIT 8741



**Ecoboiler
Ecoincinerator**

ECO Boiler NO MORE GASOLINE!

All sorts of wastes become fuels. Clean factories! Pleasant environment!
THE ECO BOILER will be with you.

APPLICABLE AREAS : Sewing, Shoes, Printing, Washing, Dyeing, Latex factories and workplace which discharges particulate or gaseous material etc.

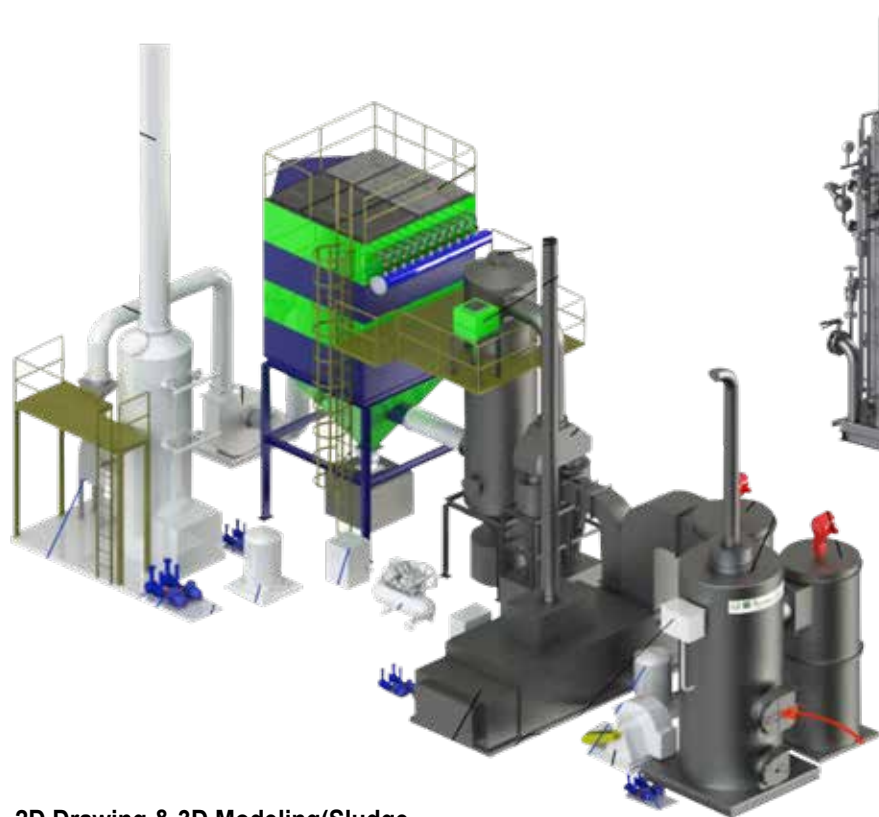

2D Drawing & 3D Modeling(Sludge incinerator Dry, Wet type)



Auto Dump System



2 Ton Vertical Type

Nissin Products & Devises

Four categories of reliable, practical, cost effective machineries: Sewing, Fusing & Pressing, Trimming & Marking and Finishing.



NC-104A
 Pneumatic bundle Clamp
 with synchronised movement



NT-756
 Collar trim, turn &
 press machine



NT-711
 Shirt placket cutting
 machine



FT-200
 Pneumatic operated shirt
 folding table



NP-758
 Auto pocket creasing
 machine



NP-798
 Cold spotting table with 2
 spotting guns, air drying gun &
 stainless steel arm



NT-726-1-11
 Three point collar
 marking machine



NF-630V
 Twin armhole buck transfer
 tape fusing machine with
 Built-in vacuum



NF-516V
 Bottom hem transfer press
 & fusing machine C/W
 Built-in vacuum



NC-123
 Automatic stacker for
 shirt placket



NF-533V
 Shirt side seam transfer tape
 fusing machine with Built-in
 vacuum



NF-558V
 Collar & cuffs transfer
 machine with Built-in
 vacuum



NUC-300/ NLC-400
 NLC-400 & NUC-300 : Lower Belt & Upper
 Hanger Conveyor System

cuTex[®]

Cutex for Velcro & Label Cutting Solutions

Cutex has made every effort to get the automatic system for sewing machinery, and products such as reagent paper cutter, deoxidizer/ sauce-pack cut & feeder, laminator for foods, and medical & packing fields.



Model: TBC 50R
Shape Cutting for Velcro



Model: TBC-52RT
Automatic Velcro Cutter



Model: TBC-50S
Automatic Printed label Cutter



Model: TBC-50S H
Automatic woven label Cutter

Products on Demand



BASS 3050
Automatic Pocket Welting Machines



Nagi Shing NS-81P Automatic Collar
Trimming, Turning and Blocking Machine



NISHO NAS-1920AEJ
Automatic Elastic Join Machine



Auto Arm Cutter



Brand Knife



Fabric Relaxing Machine



Stright Knife



End Cutter



Barrel Type Industrial Washing Machine



Dino LU-933 Automatic Rib Cutter



GJN Brand Cutting Slitter Machine



GJN Brand Fabric Forming Machine



GJN Brand Fabric Rolling Machine



Hashima Needle Detector



Industrial Dryer



Inverter Control Centrifugal Hydro Extractor



SA-5800BH Button Hole Indexer



Kansai Special-Elastic Attachment Machine



Large Area Template Sewing Machine



KEKI MJ-A02 Placket Machine



KEKI XJ-210P ELASTIC RING Machine



KM Braand Hand Cutting Machine

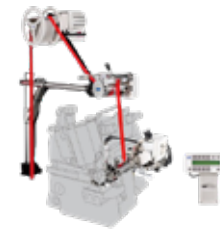

Metering Device



ST 9000 Plastic Staple Machine

Smart Tech Solution & Engineering

'Smarttech, Bangladesh Brand' has been established at year 2013, special thanks to our well knowledgeable technical team to innovate state of the art machineries in house. Our stringent efforts and an unforgettable supports from our valuable clients put a great thrust to move forward. Currently, we would like to introduce some of our products which are in operation in many factories.



FT-786
Snap Buttons Attaching



ST-BR-A/1
AUTOMATIC BRUSHING MACHINE.

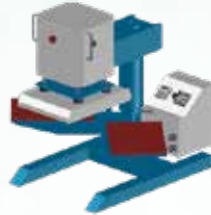

ST-HT 2030
Heat Transfer Press Machine



ST-Sdd-10
Sample Dip Dyeing Machine

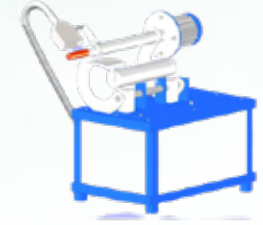

ST-11
Grinding / Destroyer Machine



ST-HT-S 150
Side Seam Covering Tape Press Machine

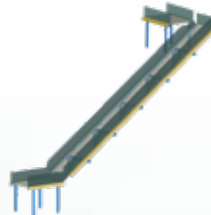

Conveyor For Loading System

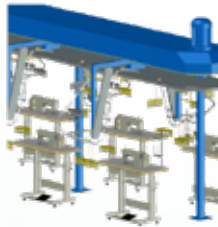

Upcoming Product Automatic Garments Hanger System



ST-HT 6050
Heat Transfer Press Machine

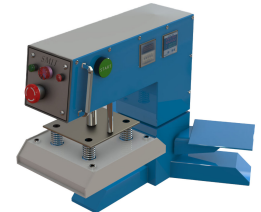

ST-HT-2015
Heat Transfer Press Machine



Heat Transfer Press Machine



Leg Press Machine

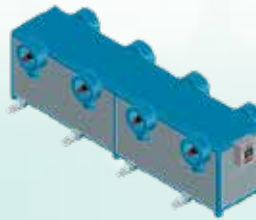

St-Gr-08
8 Stations Grinding Machine

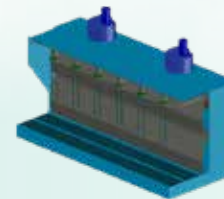

PP Spray Booth



Humidity Control Room

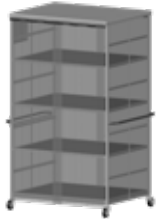

Kit Issue Trolley/Cutting Parts
Of Fabric Trolley

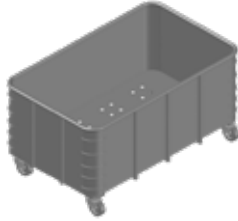

Washing Trolley

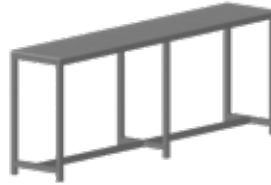

Center Table



Washing SS Dry Trolley



Complete Hanger System



Double Side Putting Cloth Rack

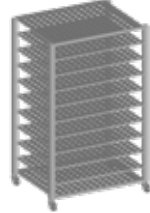

Dry Trolley

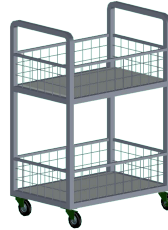

Cut Piece Trolley

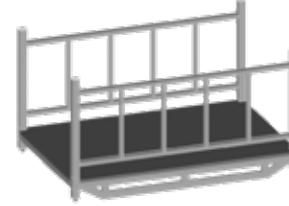

warehouse pallet



Fabric Relax Trolley



Fabric Relax Trolley2



Input Rack



Input Table



Inspection Table



Warehouse Ladder



Worker Locker



WIP Rack

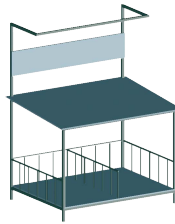

Qc Table

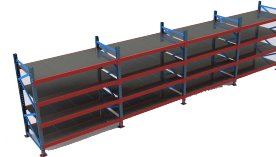

Racking System



Yarn Pallet



brother.
at your side

cuTex®

Eastman®

GROZ-BECKERT®

H&H

大族激光集团
DAZU LASER GROUP

LOIVA

Morgan Tecnica

NISSIN
日昇机械私人有限公司
NISSIN MACHINERY PTE LTD

ENIS
K O R E A
Eco boiler
Ecoincinerator

SMIT

Smarttech
Solution & Engineering Ltd
WE MAKE WE CARE

SEUNGMIN

Tonello
Garment Finishing Technologies

TRIVENETA
GRANDI IMPIANTI

VI.BE.MAC.
MEN AND TECHNOLOGY

velt

HEAD OFFICE : House # 09, Road # 03, Sector # 6, Uttara Model Town,
Dhaka-1230, Bangladesh.

Factory:
3/D Chandpara, Ziabagh,
Uzampur,
Uttarkhan, Dhaka-1230

CTG Office:
485/602, SK Mujib Road,
Chowmuhani, Chattogram,
Bangladesh

Narayanganj Office:
Holding-8, Word-9, Block-A,
Masdair, Fatullah,
Narayanganj

Hotline: +8801730034839, E-mail: info@smarttechbd.net, www.smarttechbd.net